

"V" Grooving Bits

Disposable insert router bit complete with one or two cutting flutes, designed for engraving on solid wood, hardwood and man-made boards.

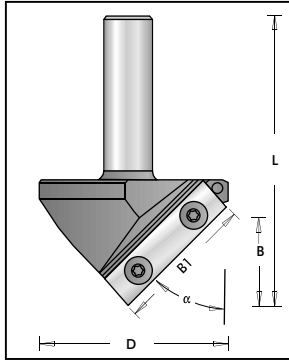
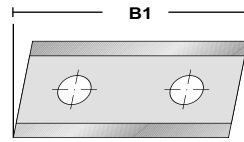

| Tool no. | D | Shank | B | B1 | α | Length | Flutes | Cat. |
|----------|---------|-------|--------|----------|----------|----------|--------|------|
| 5R8-225S | 13/16" | 1/2" | 1" | 1 1/16" | 22.5° | 2 3/8" | 1 | I |
| 5R8-25S | 7/8" | 1/2" | 31/32" | 1 1/16" | 25° | 2 9/16" | 1 | I |
| 5R8-30S | 1" | 1/2" | 15/16" | 1 1/16" | 30° | 2 3/8" | 1 | I |
| 5R8-35S | 1 1/4" | 1/2" | 7/8" | 1 1/16" | 35° | 2 9/16" | 1 | I |
| 5R8-45S | 1 1/2" | 1/2" | 3/4" | 1 1/16" | 45.5° | 3" | 1 | I |
| 5R8-50S | 1 5/8" | 1/2" | 11/16" | 1 1/16" | 50° | 3 1/4" | 1 | I |
| 5R8-55S | 1 3/4" | 1/2" | 5/8" | 1 1/16" | 55° | 3 1/4" | 1 | I |
| 5R8-60 | 2 1/32" | 1/2" | 19/32" | 1 3/16" | 60° | 3" | 2 | I |
| 5R8-65 | 2 1/8" | 1/2" | 1/2" | 1 11/64" | 65° | 3" | 2 | I |
| 5R8-75 | 2 1/4" | 1/2" | 19/64" | 1 11/64" | 75° | 2 15/16" | 2 | I |
| 5R8-80 | 2 5/16" | 1/2" | 3/16" | 1 11/64" | 80° | 2 3/4" | 2 | I |

18000
MAX. RPM

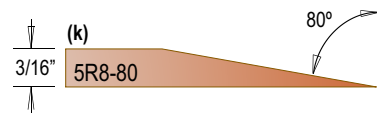
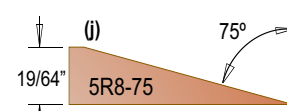
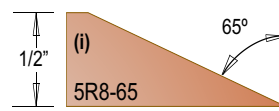
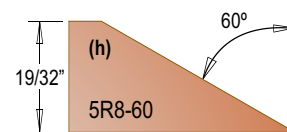
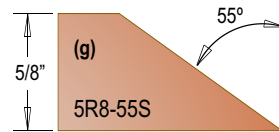
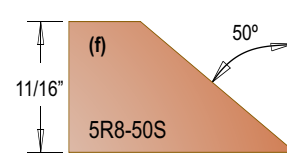
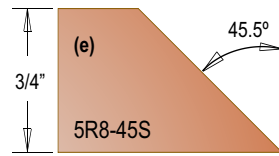
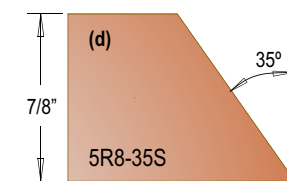
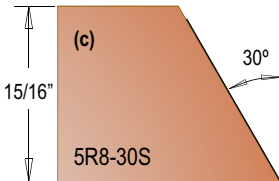
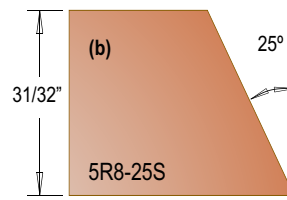
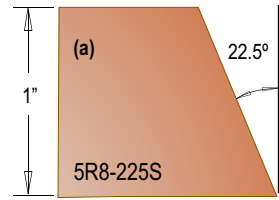

Replacement Parts:

| | T.C. Knife | Torx screw | Torx key |
|-----|------------------------|-----------------------|-----------------|
| (a) | 3105230 27x9x1.5 | 1933548 M3.5 x 4.8 | 1941015 T-15 |
| (b) | 3105230 27x9x1.5 | 1933548 M3.5 x 4.8 | 1941015 T-15 |
| (c) | 3105230 27x9x1.5 | 1933548 M3.5 x 4.8 | 1941015 T-15 |
| (d) | 3105230 27x9x1.5 | 1933548 M3.5 x 4.8 | 1941015 T-15 |
| (e) | 3105003 28x12x1.5 | 1933548 M3.5 x 4.8 | 1941015 T-15 |
| (f) | 3105003 28x12x1.5 | 1933548 M3.5 x 4.8 | 1941015 T-15 |
| (g) | 3105003 28x12x1.5 | 1933548 M3.5 x 4.8 | 1941015 T-15 |
| (h) | 3105006 29.8x12x1.5 | 1931481 M4 x 5.6 | 1941015 T-15 |
| (i) | 3105006 29.8x12x1.5 | 1931481 M4 x 5.6 | 1941015 T-15 |
| (j) | 3105005 29.8x12x1.5 | 1931482 M4 x 5.6 | 1941015 T-15 |
| (k) | 3105005 29.8x12x1.5 | 1931482 M4 x 5.6 | 1941015 T-15 |

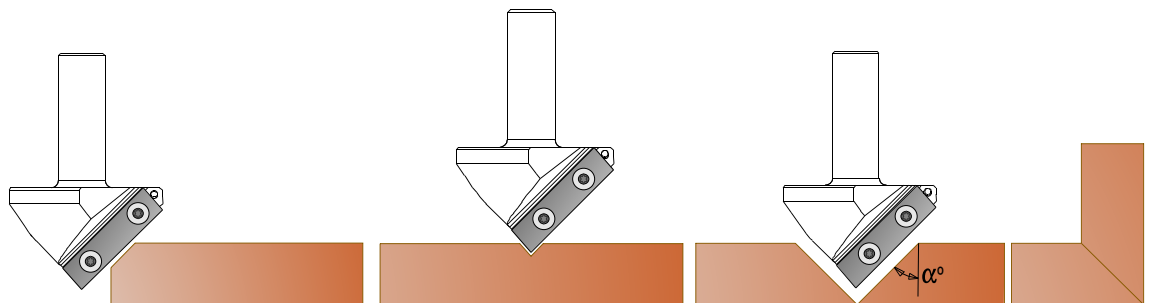

CNC Insert Carbide Knives
Designed to V-Groove
These Materials:

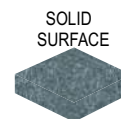
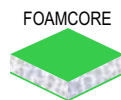
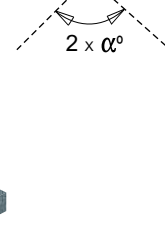
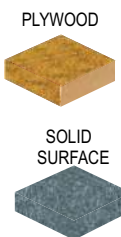
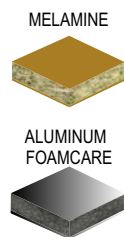
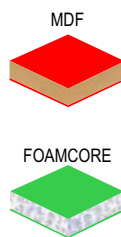

For Engraving
Only