

Tongue and Groove Cutters - Chip Limitation Design

For profile and counter-profiling of furniture framing, doors, windows etc. Recommended wood thickness 21-25mm.

Complete set includes:

- 2 cutters, tipped with 4 carbide teeth each,
- 1 Ball Bearing (7110161) which facilitates exact depth cutting of groove,
- 1 Width Spacer.

Replacement Parts: 7110161 Ball Bearing 103mm X 1.25"



Dimar's Deep Groove Ball Bearings have shields installed on both sides and are factory-packed with lubricants. It eliminates the need for relubrication and therefore, reduces maintenance costs. Dimar's selected quality ball bearings have been designed to operate at rotating speeds well above the speeds of the Shaper-Cutter Machines on the market.

Ball Bearings

Tool no.	O.D. Outside Diameter	I.D. Inside Diameter	Thickness	Category
1910230	2 1/4"	1 1/4"	1/2"	CNC
1915987	62mm	1 1/4"	15.5mm	C
1915207	98mm	1 1/4"	15.0mm	C
7110161	103mm	1 1/4"	15.0mm	C

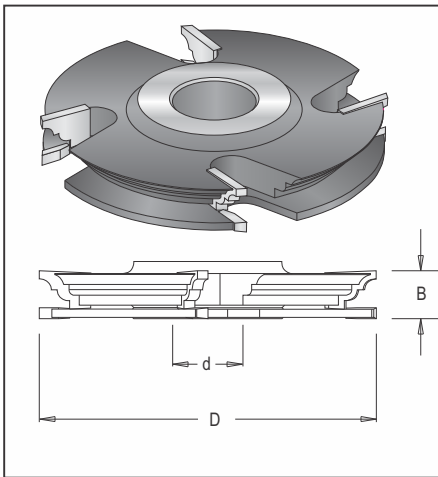

RPM 5500 - 9000

Tool no.	Diameter	Width	Bore	Teeth	Category
711M/A	125mm	15mm	1 1/4"	4+4	C

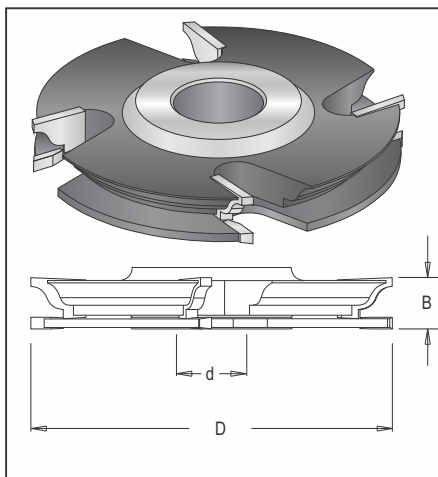
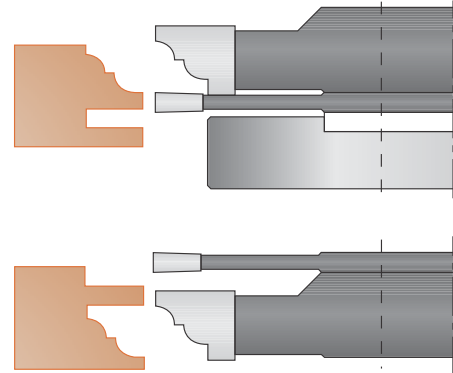
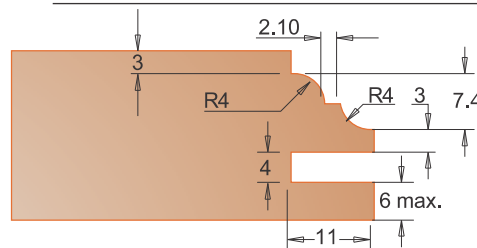

RPM 5500 - 9000

Tool no.	Diameter	Width	Bore	Teeth	Category
711M/C	125mm	16mm	1 1/4"	4+4	C

Tool no.	Description	Category
711M/C-4M	GROOVER 4mm FOR 711 M/C CUTTER	C

