

# DIROSE

1 tool, 15 different cutters!



The Dirose tool is made of high quality steel, which supports a pair of removable tungsten carbide tipped knives. The mounting is extremely accurate. Dirose can be used with a CNC machine and an accurate drill press. The choice of removable knives allows a variety of rosette patterns in many shapes and sizes. The two types of rosettes are the "inlay", giving a finished cut recessed in the material and the "button" with spurs, which cut the rosette free. A cutter head may be used with the same knives, in order to produce flat mouldings that match the style of the rosettes. Blank knives are available for custom designs.

Tool no.	Description	Category
D-1	A set with: 1 Rosette Bit and 5 pairs of knives	Q
D-2	A set with: 1 Rosette Bit, 1 Cutter Head 3/4" Bore and 5 pairs of knives	Q
D-3	A set with: 1 Rosette Bit, 1 Cutter Head 1" Bore and 5 pairs of knives	Q
D-4	A set with: 1 Rosette Bit, 1 Cutter Head 1 1/4" Bore and 5 pairs of knives	Q

The above sets include an attractive wooden case, 1 Allen key (1940090) and the following pairs of knives: 1800010, 1800020, 1800030, 1800050 and 1800100.

**Additional knives as per listing below**

Tool no.	Description	Category
1800010	Carbide Tipped DIROSE Knife	Q
1800020	Carbide Tipped DIROSE Knife	Q
1800030	Carbide Tipped DIROSE Knife	Q
1800040	Carbide Tipped DIROSE Knife	Q
1800050	Carbide Tipped DIROSE Knife	Q
1800060	Carbide Tipped DIROSE Knife	Q
1800070	Carbide Tipped DIROSE Knife	Q
1800080	Carbide Tipped DIROSE Knife	Q
1800090	Carbide Tipped DIROSE Knife	Q
1800100	Carbide Tipped DIROSE Knife	Q
1800110	Carbide Tipped DIROSE Knife	Q
1800120	Carbide Tipped DIROSE Knife	Q
1800130	Carbide Tipped DIROSE Knife	Q
1800140	Carbide Tipped DIROSE Knife	Q
1800150	Carbide Tipped DIROSE Knife	Q

**Blank Knives For Custom Profiles, Carbide Tipped**

Tool no.	LengthxWidthxThickness	Category
4180025	25mm x 1" x 1/4"	Q
4180030	30mm x 1" x 1/4"	Q
4180035	35mm x 1" x 1/4"	Q
4180040	40mm x 1" x 1/4"	Q
4180045	45mm x 1" x 1/4"	Q
4180050	50mm x 1" x 1/4"	Q

Please note:  
**The DIROSE bit is designed to work mainly in man-made materials, such as MDF and Particle Board.**

To achieve good results with natural woods, test several spindle speeds & feed rates.

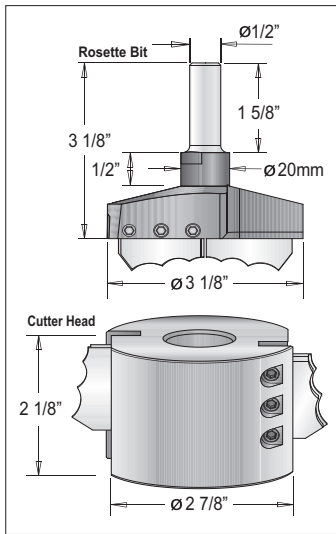

Rosette bit and cutter head require two knives.

## DIROSE Components

Tool no.	Description	Category
1080018	Rosette Bit 1/2" Shank	Q
1800023	DIROSE Cutter Head, 3/4" Bore	Q
1800025	DIROSE Cutter Head, 1" Bore	Q
1800027	DIROSE Cutter Head, 1 1/4" Bore	Q



Allen key  
1940090



Arbor shank -1/2"  
1905008



Allen screw  
1930650

### Rosette Bit

MDF Max. 3,000-6,000 RPM; Softwood Max. 3,000-6,000 RPM  
Hardwood Max. 1,500-2,000 RPM

### Cutter Head

Max. 10,000 RPM; Recommended 6,000-8,000 RPM  
Diameter = 2 15/16: Height = 2 1/8"

