

Raised Panel Cutter

Wear resistant aluminum body, complete with replaceable solid tungsten carbide knives. Suitable for producing various raised profiles in softwood, hardwood and man-made boards on a spindle moulder. Same tool body accepts all three different profiles.

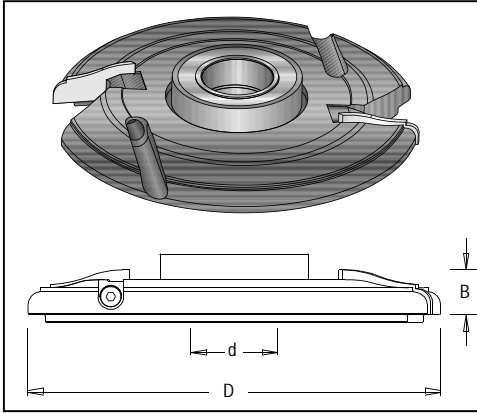
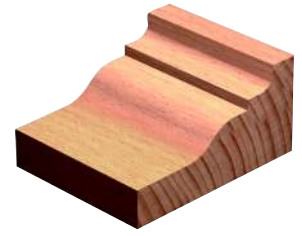

Tool no.	D	d	B	Profile	Category
K126C-1	156mm	1 1/4"	17mm	1	CNC
K126C-2	156mm	1 1/4"	17mm	2	CNC
K126C-3	156mm	1 1/4"	17mm	3	CNC
K126C-SET	156mm	1 1/4"	17mm	1+2+3	CNC

Ball Bearing (SOLD SEPARATELY)

Tool no.	O.D. Outside Diameter	I.D. Inside Diameter	Thickness	Category
1910230	2 1/4"	1 1/4"	1/2"	CNC

5000-9000 RPM

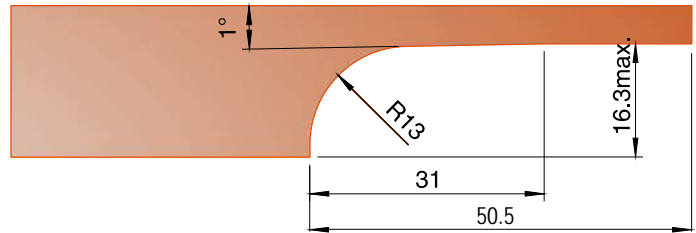
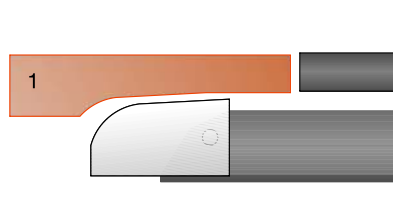

Replacement Parts:



T.C. Blade #1
3108310



Wedge
1998040



Allen Screw
1930267



Allen Key
1940037



Ball Bearing
1910230

Price per single knife.

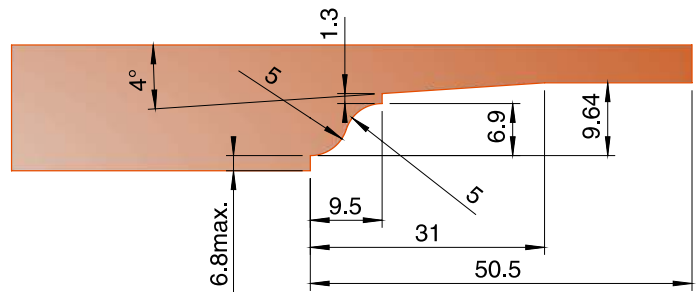
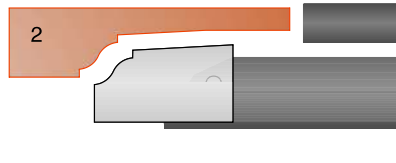

Replacement Parts:



T.C. Blade #2
3108311



Wedge
1998040



Allen Screw
1930267



Allen Key
1940037



Ball Bearing
1910230

Price per single knife.

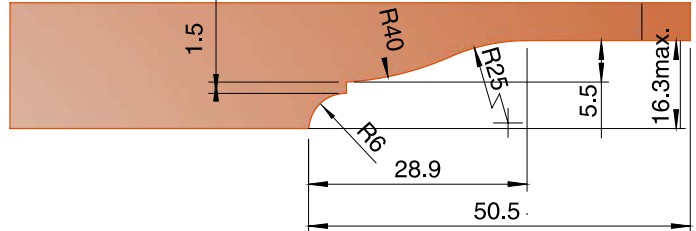
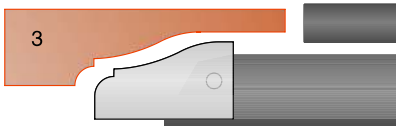

Replacement Parts:



T.C. Blade #3
3108312



Wedge
1998040



Allen Screw
1930267



Allen Key
1940037



Ball Bearing
1910230

Price per single knife.