

### Raised Panel Cutter

Wear resistant aluminum body, complete with two replaceable solid tungsten carbide knives and two scribes. Suitable for producing various raised panel profiles in softwood, hardwood and man-made boards on a spindle moulder. Raising or lowering the cutter on the spindle moulder produces different profiles. Each cutter comes fully assembled with knives to produce all four profiles shown, by simply adjusting the small knife up or down.

Instructions included.

**Please note:** Cutters K200A and K200B have different bodies therefore knives cannot be interchanged.

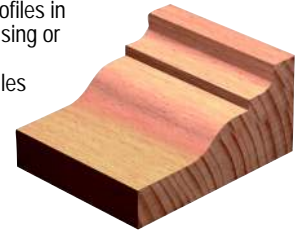

Tool no.	D	d	B	Teeth	t	RPM	Category
K200A	200mm	1 1/4"	20mm	2+2	63mm	3,800 - 6,500	CNC
K200B	200mm	1 1/4"	24mm	2+2	63mm	3,800 - 6,500	CNC

### Ball Bearing (SOLD SEPARATELY)

Tool no.	O.D. Outside Diameter	I.D. Inside Diameter	Thickness	Category
1910230	2 1/4"	1 1/4"	1/2"	CNC

K200A

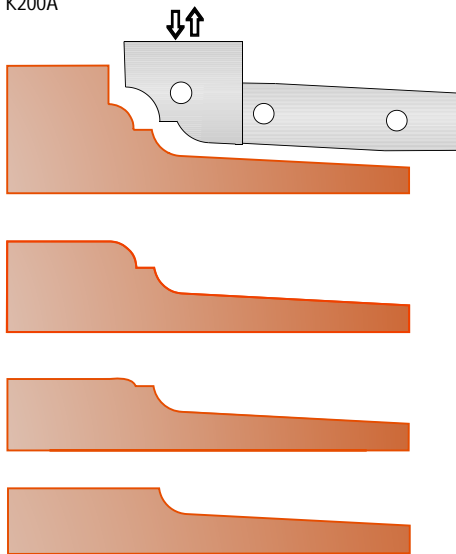

K200B

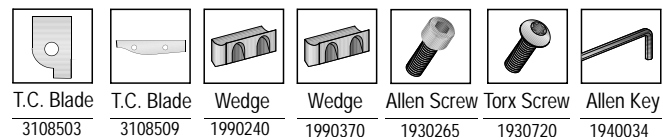
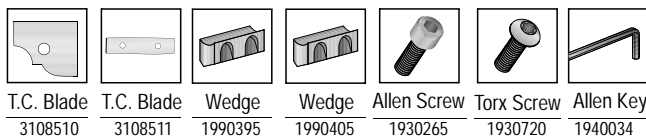
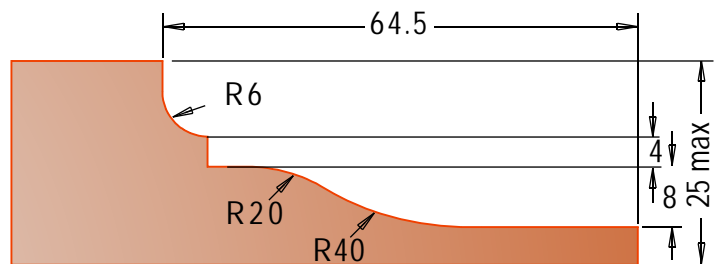
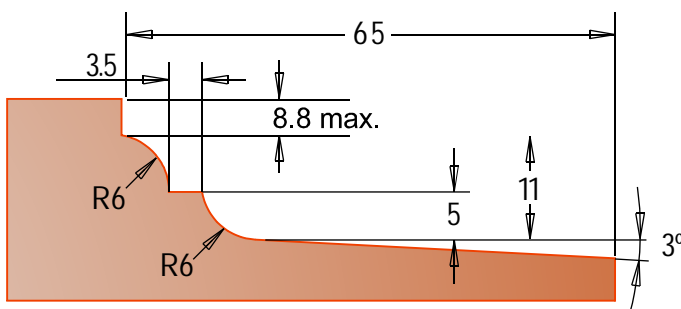
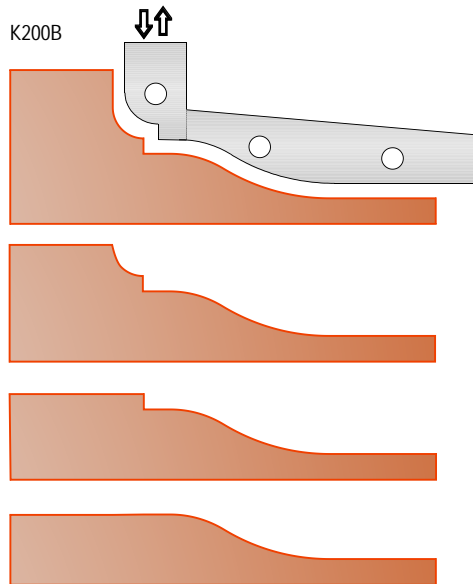

Price per single knife.



#### Bushings for K200A Cutter

Tool no.	O.D.	I.D.	Thickness	Category
1925150	1 1/4"	3/4"	3/4"	C
1925250	1 1/4"	1"	3/4"	C

#### Bushings for K200B Cutter

Tool no.	O.D.	I.D.	Thickness	Category
1925160	1 1/4"	3/4"	9/16"	C
1925260	1 1/4"	1"	9/16"	C