

Edge Forming Bits, 2 Flutes

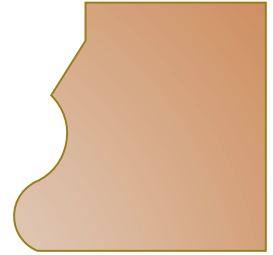

Tool no.	D	Shank	B	Length	Category
156R8-54	1 3/8"	1/2"	1 1/2"	3 3/8"	R

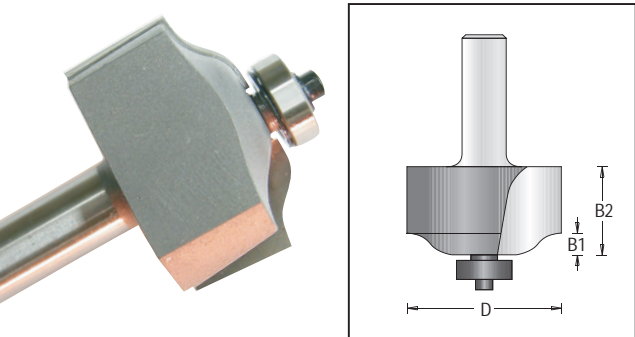

Edge Forming Bits, 2 Flutes

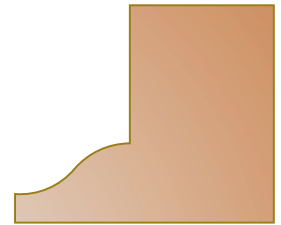

Tool no.	D	Shank	B1	B2	Length	Category
156R8-60	1 3/4"	1/2"	1/4"	1"	3"	R

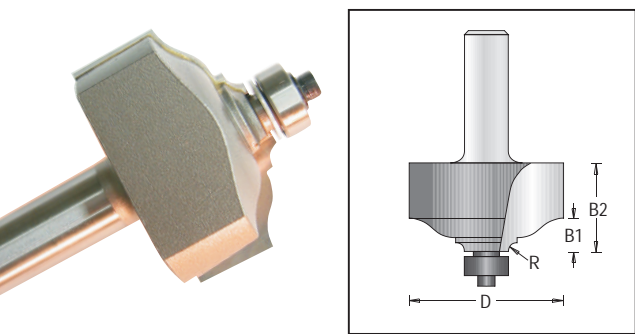

Edge Forming Bits, 2 Flutes

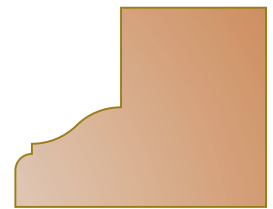

Tool no.	D	Shank	B1	B2	R	Length	Category
156R8-61	1 3/4"	1/2"	3/8"	1"	3/32"	3"	R

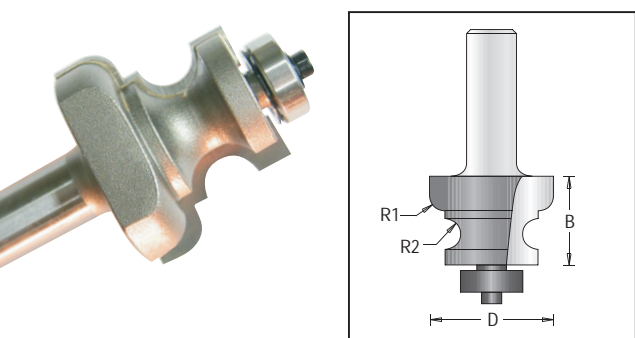

Edge Forming Bits, 2 Flutes

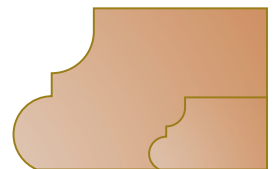

Tool no.	D	Shank	B	R1	R2	Length	Category
156R8-19	13/16"	1/2"	19/32"	5/64"	5/64"	2 1/2"	R
156R8-20	1 1/4"	1/2"	7/8"	5/32"	5/32"	2 3/4"	R
156R8-21	1 9/16"	1/2"	1 3/16"	7/32"	3/16"	3 1/16"	R

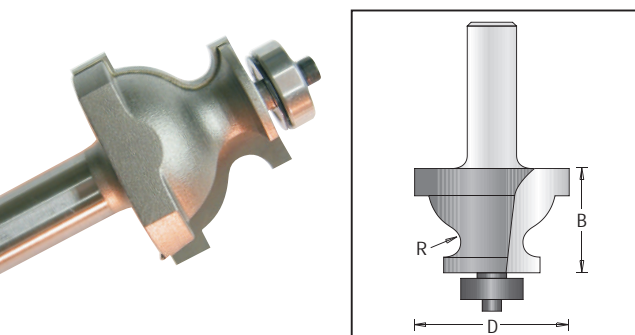

Edge Forming Bits, 2 Flutes



Tool no.	D	Shank	B	R	Length	Category
156R8-41	1 9/16"	1/2"	1 1/16"	5/32"	3"	R