

Carbide Tipped Miter Saw Blade, Thin Kerf

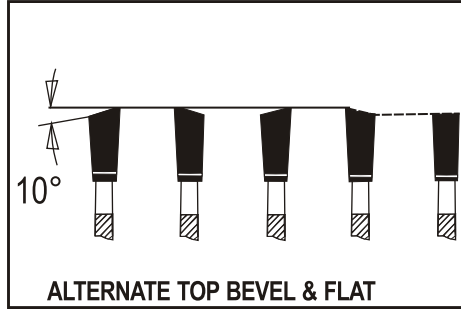
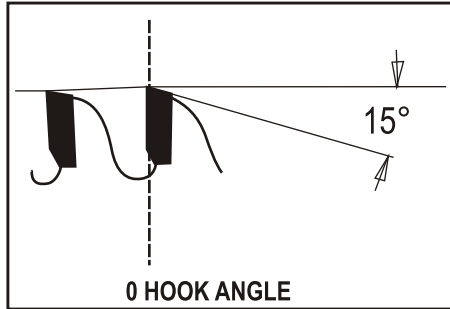

For cutting across and along the grain in wood, plywood, hardboard and particle board. Used in sliding, compound, miter saws and radial arm saws. Micro-grain Titanium carbide teeth. Non-Adhesive black coating. Thick carbide teeth. Premium quality. Made in Germany.

Tool no.	Dia.	Teeth	Kerf	Bore	Category
WP1270A	12"	70	.110" (2.8mm)	1"	WP