









## Adjustable Grooving and Rebating Cutter with scorers 20.6 - 100mm

Wear resistant steel body complete with replaceable solid tungsten carbide knives and scorers for improved finish. Suitable for producing various thickness grooves and slots in softwood, hardwood and man-made boards (with or without coating) on a spindle moulder. Cutting width can be adjusted in 0.1mm increments by using supplied spacer rings.

Tool no.	D	d	B	Teeth	t	RPM	Category
K8C160-20	160mm	1 1/4"	20.6 - 40mm	4+4	40mm	4,800 - 8,000	CNC
K8C160-30	160mm	1 1/4"	30.6 - 60mm	4+4	40mm	4,800 - 8,000	CNC
K8C160-50	160mm	1 1/4"	50.6 - 100mm	4+4	40mm	4,800 - 8,000	CNC
K8C200-20	200mm	1 1/4"	20.6 - 40mm	4+4	50mm	4,000 - 6,500	CNC
K8C200-30	200mm	1 1/4"	30.6 - 60mm	4+4	50mm	4,000 - 6,500	CNC
K8C200-50	200mm	1 1/4"	50.6 - 100mm	4+4	50mm	4,000 - 6,500	CNC

### Replacement Parts:

							
T.C. Blade	Wedge	T.C. Blade	Spacer Set	Torx Screw	Allen Screw	Torx Key	Allen Key
3101220	1990330	3008503	1926937	1933700	1930265	1941060	1940035
3101230	1990510	3008503	1926987	1933700	1930265	1941060	1940035
3101250	1990480	3008503	1926997	1933700	1930265	1941060	1940035

Price per single knife.

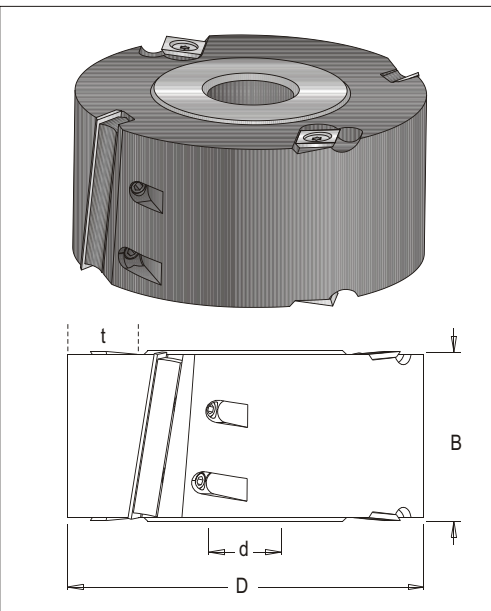







## Rebating Cutter

Wear resistant aluminum or steel bodies, complete with shear angled replaceable solid tungsten carbide knives and scorers. Suitable for producing various rebates in softwood, hardwood and man-made boards (with or without coating) on a spindle moulder. Shear angle reduces tearout and improves quality & feed rate of cut.

Tool no.	D	d	B	Teeth	t	RPM	Category
K14C125-30	125mm	1 1/4"	30mm	4+4	27mm	6,100 - 10,300	CNC
*K14C125-50A	125mm	1 1/4"	50mm	2+4	27mm	6,100 - 10,300	CNC
K14C125-50	125mm	1 1/4"	50mm	4+4	27mm	6,100 - 10,300	CNC
*K14C125-60A	125mm	1 1/4"	60mm	2+4	27mm	6,100 - 10,300	CNC
*K14C150-60A	150mm	1 1/4"	60mm	2+4	40mm	5,200 - 8,600	CNC

±10° Shear Face Angles. \* Aluminum

### Replacement Parts:

						
T.C. Blade	Wedge	T.C. Blade	Torx Screw	Allen Screw	Torx Key	Allen Key
B = 30mm 3101230	1990275	3008503	1933700	1930265	1941060	1940035
B = 50mm 3101250	1990450	3008503	1933700	1930650	1941060	1940035
B = 60mm 3000531	1990336	3008503	1933700	1930265	1941060	1940035

Price per single knife.

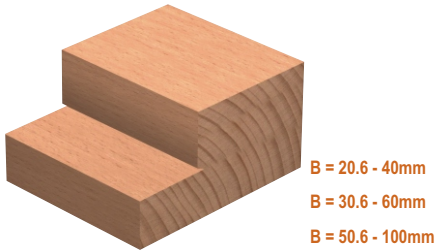

B = 20.6 - 40mm  
B = 30.6 - 60mm  
B = 50.6 - 100mm

