

Grooving Cutters with Spurs - Chip Limitation Design

Carbide Tipped: four Teeth & four Spurs for cutting grooves across the grain

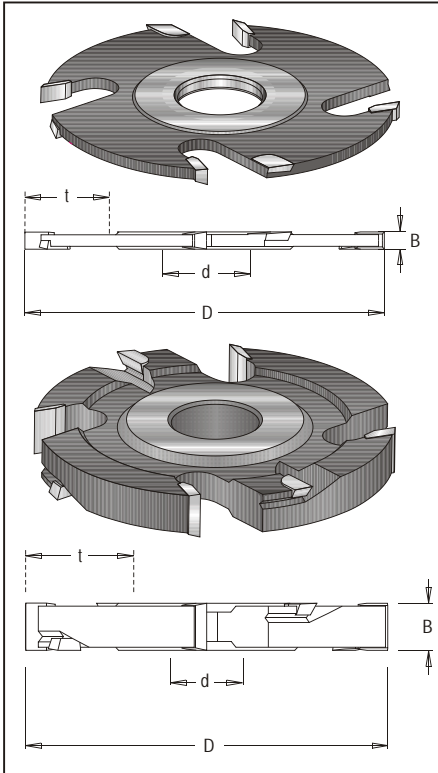

Tool no.	D	d	B	Teeth	t	Category
707NF-125-4	125mm	1 1/4"	5/32"	4+4	32mm	C
707NF-125-5	125mm	1 1/4"	3/16"	4+4	32mm	C
707NF-125-6	125mm	1 1/4"	1/4"	4+4	32mm	C
707NF-125-8	125mm	1 1/4"	5/16"	4+4	32mm	C
707NF-125-10	125mm	1 1/4"	3/8"	4+4	32mm	C
707NF-125-12	125mm	1 1/4"	1/2"	4+4	32mm	C
707NF-125-14	125mm	1 1/4"	9/16"	4+4	32mm	C
707NF-125-16	125mm	1 1/4"	5/8"	4+4	32mm	C
707NF-150-4	150mm	1 1/4"	5/32"	4+4	45mm	C
707NF-150-5	150mm	1 1/4"	3/16"	4+4	45mm	C
707NF-150-6	150mm	1 1/4"	1/4"	4+4	45mm	C
707NF-150-8	150mm	1 1/4"	5/16"	4+4	45mm	C
707NF-150-10	150mm	1 1/4"	3/8"	4+4	45mm	C
707NF-150-12	150mm	1 1/4"	1/2"	4+4	45mm	C
707NF-150-16	150mm	1 1/4"	5/8"	4+4	45mm	C

D=125 RPM 6200-10500

D=150 RPM 5200-9000

