

Finishing Blades, Carbide Tipped Saw Blade (TCG)

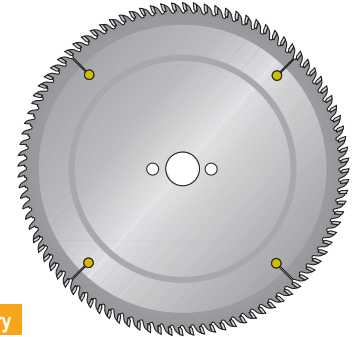

Tool no.	Dia.	Teeth	Kerf	Bore	Category
1080TD	10"	80	.126" (3.2mm)	5/8"	W
* 1272TD	12"	72	.126" (3.2mm) (Altendorf/Felder)	30mm+2 PH	W
1296TD	12"	96	.126" (3.2mm)	1"	W
14-72TD-30	14"	72	.138" (3.5mm)	30mm+2 PH	W
1484TD	14"	84	.138" (3.5mm)	1"	W
14108TD	14"	108	.138" (3.5mm)	1"	W

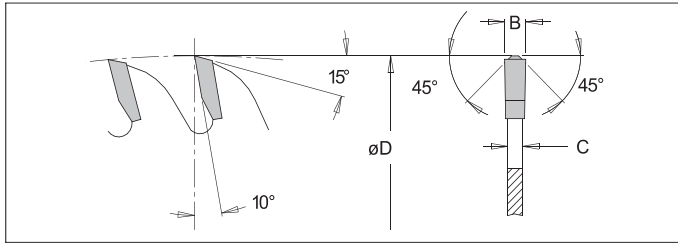

The Ultimate Sawing Blades

- Special dynamic balancing
- Unique straightening operation
- Long-lasting quality cut
- Low noise level

Special dynamic balancing. Unique straightening operation. Long-lasting quality cut. Low noise level



Manufacturing Technology:

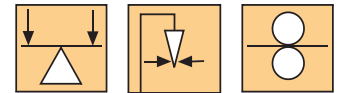

Dynamic Balancing

Dynamic Straightness

Tension



*Altendorf /
Felder



**Boards & Veneered
Boards:**
Across & Along