

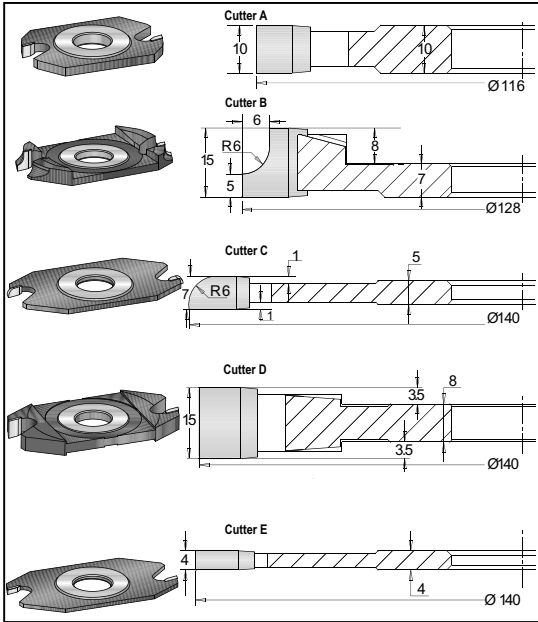

# MULTICUT



## Multi Profile Cutter - Chip Limitation Design



Tool no.	Cutter	Diameter	Width	Bore	Max. Depth
MULTICUT	Complete Set, 5 cutters with all Spacers				
MULTI-A	A	116mm	10mm	1 1/4"	28mm
MULTI-B	B	127mm	15mm	1 1/4"	34mm
MULTI-C	C	140mm	6mm	1 1/4"	40mm
MULTI-D	D	140mm	15mm	1 1/4"	40mm
MULTI-E	E	140mm	4mm	1 1/4"	40mm

Dimar's "Multicut" Profile Cutter consists of 5 Carbide Tipped Cutters, each with 2 teeth. The set enables execution of various profiles, counter profiles and raised panels.

**RPM 6500-11000**

Each MULTICUT contains 1 set of metal spacer rings

Tool no.	Spacers	Category
7110657	Complete Set	C
	4 x 1927101 - 0.1mm	
	3 x 1927021 - 0.2mm	
	1 x 1927031 - 0.3mm	
	2 x 1927041 - 0.4mm	
	1 x 1927341 - 3.4mm	
	1 x 1927651 - 6.5mm	

