

Convex Profile Cutter

Wear resistant aluminum or steel bodies, complete with replaceable solid tungsten carbide knives. Suitable for producing various coves in softwood, hardwood and man-made boards on a spindle moulder.

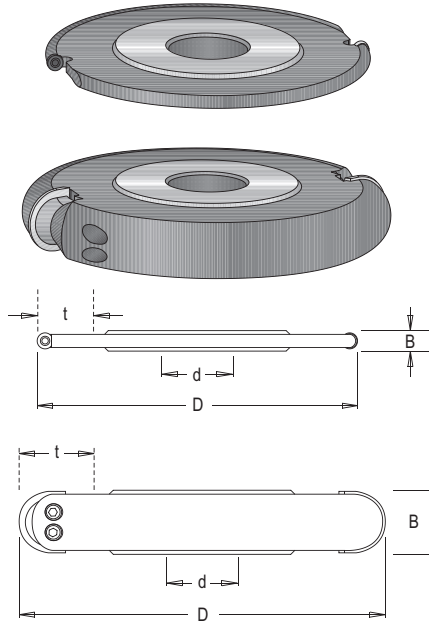

Tool no.	D	d	B	R	Teeth	t	RPM	Category
K169C126-3	126mm	1 1/4"	6mm	3mm	2	28mm	4,500 - 10,600	CNC
K169C128-4	128mm	1 1/4"	8mm	4mm	2	29mm	4,500 - 10,600	CNC
K169C130-5	130mm	1 1/4"	10mm	5mm	2	30mm	4,500 - 10,600	CNC
*K169C132-6	132mm	1 1/4"	12mm	6mm	2	31mm	5,700 - 10,100	CNC
*K169C136-8	136mm	1 1/4"	16mm	8mm	2	33mm	5,600 - 8,400	CNC
*K169C140-10	140mm	1 1/4"	20mm	10mm	2	35mm	5,400 - 9,500	CNC
*K169C144-12	144mm	1 1/4"	24mm	12mm	2	37mm	5,300 - 9,200	CNC
*K169C150-15	150mm	1 1/4"	30mm	15mm	2	40mm	5,000 - 8,900	CNC
*K169C160-20	160mm	1 1/4"	40mm	20mm	2	45mm	4,700 - 8,000	CNC

Replacement Parts:



T.C. Blade



Wedge



Torx Screw



Torx Key



Allen Screw



Allen Key

R = 3mm	3000400		
R = 4mm	3000402		
R = 5mm	3000403		
R = 6mm	3006506	1990501	
R = 8mm	3006508	1990502	
R = 10mm	3006510	1990503	
R = 12mm	3006512	1990504	
R = 15mm	3006515	1990505	
R = 20mm	3006520	1990506	

1934200	1941110
1934250	1941100
1934300	1941015

1930265	1940035
1930265	1940035
1930265	1940035
1930265	1940035
1930265	1940035
1930265	1940035