

Manufacturing Technology:



Balance



Straight



Tension



Universal:
Across &
Along

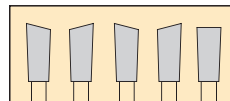
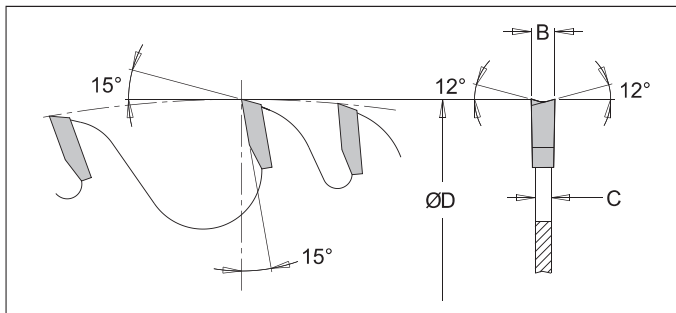

Combination Saw Blades (COM)

All purpose blade designed for ripping, cutting along and across the grain for easy feed in softwood, hardwood, plywood, chipboard and particle board. The fifth raker tooth is designed to give a clean medium quality cut. For radial arm and table saws.

Tool no.	Dia.	Teeth	Kerf	Bore	Category
8-40 COM	8"	40	.126" (3.2mm)	5/8"	S
9-40 COM	9"	40	.126" (3.2mm)	5/8"	S
10-50 COM	10"	50	.134" (3.4mm)	5/8"	S
*10-50 CL	10"	50	.126" (3.2mm)	5/8"	S
12-60 COM	12"	60	.149" (3.8mm)	1"	S
14-70 COM	14"	70	.149" (3.8mm)	1"	S
16-80 COM	16"	80	.157" (4.0mm)	1"	S

* Chip Limitation for Radial Arm Saw