

Sawblades for Cutting and Grooving

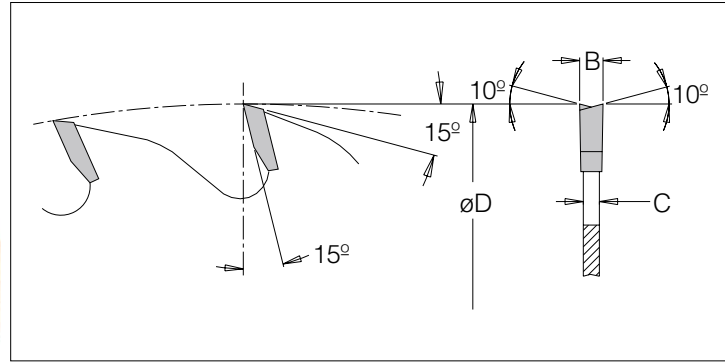

Tungsten carbide tipped alternate bevel saw blades for cutting and grooving along and across the grain on softwoods, hardwoods and man-made boards (with or without coating).
For use on routers and machining centres with CNC Control.

Tool no.	Dia.	Teeth	Kerf	C	RPM	Max t.	Bore	Category
125243	125mm	24	3mm	2.0mm	19,000	25mm	30	CNC
125244	125mm	24	4mm	2.8mm	19,000	25mm	30	CNC
125245	125mm	24	5mm	3.5mm	19,000	25mm	30	CNC
150243	150mm	24	3mm	2.0mm	9,000	38mm	30	CNC
150244	150mm	24	4mm	2.8mm	9,000	38mm	30	CNC
150245	150mm	24	5mm	3.5mm	9,000	38mm	30	CNC
180303	180mm	30	3mm	2.0mm	7,000	54mm	30	CNC
180304	180mm	30	4mm	2.8mm	7,000	54mm	30	CNC
180305	180mm	30	5mm	3.5mm	7,000	54mm	30	CNC

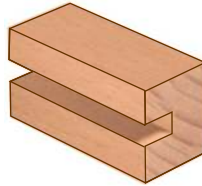
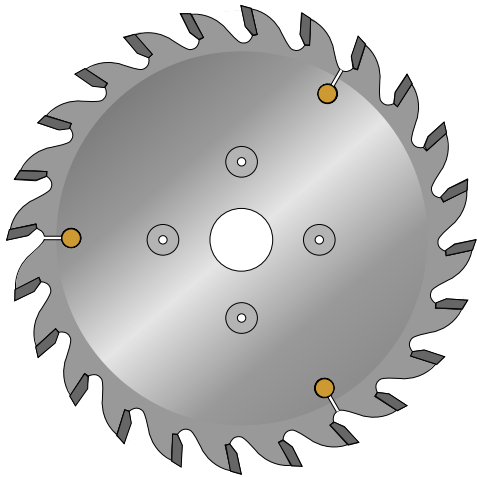
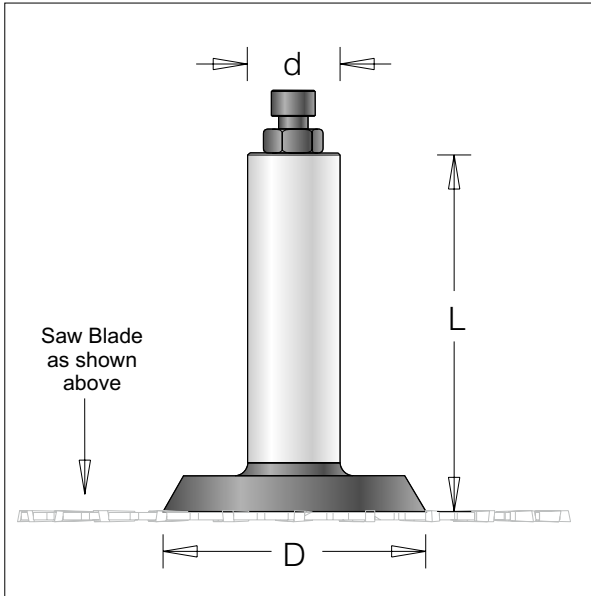

CNC Arbor

Tool no.	Dia	d	L		Category
1900250	71mm	20mm	90mm	4 x M5 x ø52	CNC
190025H	71mm	25mm	90mm	4 x M5 x ø52	CNC
1900252	71mm	3/4"	90mm	4 x M5 x ø52	CNC

Replacement Parts



Allen screw
1930426
M5 x 12



Allen Key
1940035
S3

