

## Planing and Rebating Router Cutter

Disposable insert planing and rebating router bit with two cutting flutes and two scorers. Suitable for planing and rebating in softwoods and hardwoods and man-made boards. A good tool for fast removal of material over a large surface area. Scorers will improve finish at the bottom of the cut. For use on CNC routers.

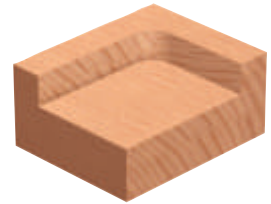

Tool no.	D	Shank	B	Length	Cat.
N163R19-80	80mm	3/4" x 60mm	12mm	90mm	CNC
N163R20-80	80mm	20mm x 60mm	12mm	90mm	CNC

Knives sold in lots of 10 pieces.

Price per single knife.



T.C. Knife  
L12



T.C. Knife  
L142



Torx screw  
1933950



Torx screw  
1933700



Torx key  
1941015



Torx key  
1941060

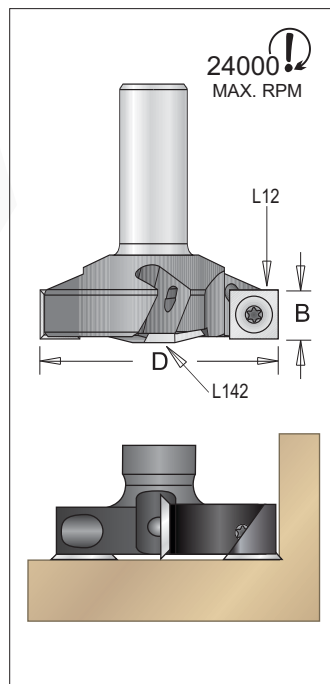

## Spoil board Surfacing and Routing Cutter

Disposable insert planing and rebating router bit with two cutting flutes and two scorers. Suitable for planing and rebating in softwoods and hardwoods and man-made boards. A good tool for fast removal of material over a large surface area.

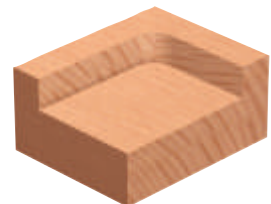

Scorers will improve finish at the bottom of the cut. For use on CNC routers.

Tool no.	D	Shank	B	Length	Category
N163R8-39	39.10mm	1/2"	12mm	58mm	CNC
N163R8-64	2 35/64"	1/2"	12mm	2 31/64"	CNC

Knives sold in lots of 10 pieces.

Price per single knife.



T.C. Knife  
L12



T.C. Knife  
L142



Torx screw  
1933950



Torx screw  
1933700



Torx key  
1941015  
T15



Torx key  
1941060  
T20