

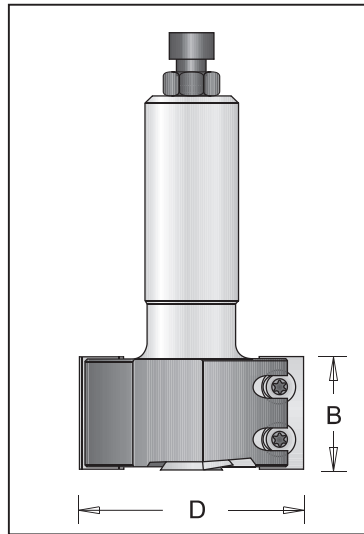

18000!
MAX. RPM



Straight Rebater Router Cutter with Scorers

Disposable insert rebating router bit complete with two cutting edges and scorers. Suitable for trimming and rebating in softwoods, hardwoods and man-made boards. Scorers will improve finish at the bottom of the cut. For use on CNC routers.

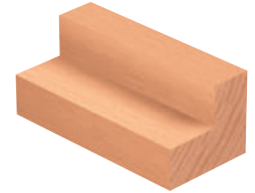

Tool no.	D	Shank	B	Length	Parts	Cat.
N114R19-40	40mm	3/4"	30mm	100mm	20	CNC
N114RL19-40	40mm	3/4" x 55mm	50mm	120mm	21	CNC
N114R19-60	60mm	3/4" x 55mm	30mm	100mm	20	CNC
N114RL19-60	60mm	3/4" x 55mm	50mm	120mm	21	CNC
N114R20-40	40mm	20mm x 55mm	30mm	100mm	20	CNC
N114RL20-40	40mm	20mm x 55mm	50mm	120mm	21	CNC
N114R20-60	60mm	20mm x 55mm	30mm	100mm	20	CNC
N114RL20-60	60mm	20mm x 55mm	50mm	120mm	21	CNC



Replacement Parts

Parts #	TC Knife (mm)	Special Blade TC Knife (mm)	Torx Screw	Torx Screw	Allen/Torx Key
20	L30 30x12x1.5	L142 14x14x2	1931481	1933700	1941015 1941060
21	L50 50x12x1.5	L142 14x14x2	1931481	1933700	1941015 1941060



12000!
MAX. RPM

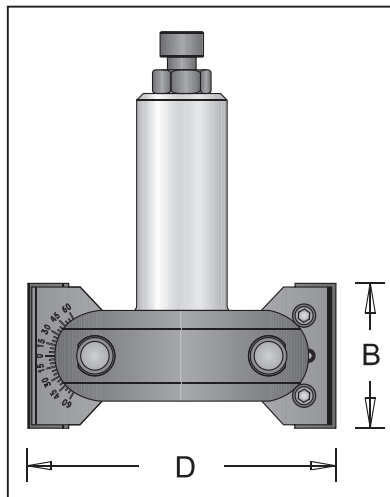

Adjustable Bevel Router Cutter, 2 Flutes

Disposable insert router bit with two flutes. Suitable for producing chamfer cuts at various angles in softwoods, hardwoods and man-made boards. Fast tuning angle of 7.5° steps. Fine tuning angle of 1°. For use on CNC routers.

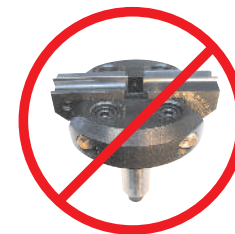

Tool no.	D	Shank	B	a	Length	Parts	Cat.
N102R19-45	85mm	3/4"	40mm	-45° - +90°	100mm	19	CNC
N102R20-45	85mm	20mm	40mm	-45° - +90°	100mm	19	CNC

Fast tuning angle of 7.5° step. Fine tuning angle of 1°



Replacement Parts

Parts #	TC Knife (mm)	Special Blade TC Knife (mm)	Allen Screw	Allen/Torx Key	Wedge	Wedge Lock
19	3000528 40x12x1.5 35° 26 c.c.	L142 14x14x2	1930494 1930265	1940035 1940036	1990820	1994031